

Now with  
Environmental Profile,  
Green Guide ratings &  
Ecopoint scores

# Roof Slate

Zeeland  
fibre cement slate with textured surface



# Zeeland slates

The Cembrit group have been manufacturing and developing fibre cement products, including slates for over 80 years.

Cembrit prides itself on manufacturing fibre cement slates which achieve the highest approvals from local, national and international agencies in the fields of product quality and sustainability.

Cembrit fibre cement slates are complemented by a range of fibre cement ridges, details of which are available in the Roof Slate Accessories brochure.

Cembrit slates and ridges can be found on all types of roofs across the British Isles.

Information on the complete Cembrit range appears on our website



Certificate No. ENP 441 28 October 2011

Zeeland slates have an appearance close to that of sawn edge natural slate. Their attractive riven surface and clean square edges make them an ideal solution for situations where presentation is important. They are manufactured to the highest European standards and are lightweight, pre-holed, suitable for all types of projects, easy to handle and install, durable and an economic alternative to natural roofing materials. Zeeland slates are manufactured using Portland cement together with a non-asbestos formulation of superior blended synthetic and cellulose fibres. Zeeland slates are pigmented during production and are fully compressed. They are finished with a high quality, semi-matt acrylic coloured coating to the top face and edges and a tinted, high performance binder to the back face.

#### Quality assurance

Zeeland slates are manufactured in accordance with a quality assurance system to ISO 9001 and to the requirements of BS EN 492:2004 product specification for fibre cement slates and their fittings. Zeeland slate has been awarded the BBA Certificate No. 03/4041. The slates have been tested by Birmingham City Laboratories and approved for use on Birmingham City Council projects and accepted by many other local authorities.

#### Environment

Environmental Management

Zeeland slates are manufactured in a factory which complies with the requirements of ISO 14001:2004, and has been awarded certificate number E-0394C/14

#### Life-cycle assessment (LCA)

Cembrit's Czech produced fibre cement slates have been awarded an Environmental Profile Certificate by BRE Global and are listed on the greenbooklive.com website. Incorporating Zeeland fibre cement slates in Green Guide pitched roof specification elements 1112410003-5 will allow specifiers to achieve the highest A+/A ratings depending on the element. Ecopoint scores from cradle to grave for 1m<sup>2</sup> of Zeeland slates over a 60 year life range from 0.34 to 0.51 depending on the element specified.

## Appearance

Zeeland slates are available in 600 x 300mm format in Blue/Black and Graphite colours with a textured surface.



Blue / Black



Graphite

## Performance

### Compatibility

Zeeland slates are compatible with most common building materials, except those vulnerable to alkaline attack. When materials such as aluminium are used as flashings or gutters they should be protected and maintained with bituminous paint if they will be subject to water run-off from the slates.

### Tolerances

Zeeland slates are made to the following dimensional tolerances in accordance with BS EN 492: 2004.

Length or width:  $\pm 3.0\text{mm}$  Thickness:  $4\text{mm} + 1.0\text{mm}, - 0.4\text{mm}$

### Strength

Zeeland slates exceed the requirements of Class B (the highest) of BS EN 492: 2004 giving an average bending moment greater than 50 Nm/m.

### Density

Zeeland slates have an average density of 1850 kg/m<sup>3</sup> when tested to BS EN 492: 2004 section 7.3.1.

### Fire

Zeeland slates achieve the following ratings:

BS 476: Part 2: 1989 and BS 476: Part 7: 1987. Fire Propagation Index (I) of 0.9, a Sub index (ii) of 0.3 and a Class I surface.

Class 0 surface as defined in the various national Building Regulations.

BS 476: Part 3 1958 EXT. SAA

BS 476: Part 3 1975 Class P60

### Frost

Zeeland slates show satisfactory frost resistance after 100 freeze/thaw cycles and satisfy the requirements of BS EN 492: 2004 section 7.4.1.

### Thermal

The coefficient of linear expansion of Zeeland slates is approximately  $8 \times 10^{-6} \text{ mm/}^\circ\text{C}$ . This is equivalent to an expansion of 0.08mm/m for a 10°C temperature change. Thermal conductivity (k value) is 0.35W/m°C.

### Effects of chemicals

During tests Zeeland slates have been found to have a good resistance to chemical attack, however it should be noted that prolonged exposure will cause surface degradation. In areas where this may be excessive please consult Cembrit Ltd. for further advice.

### Biological

Zeeland slates are vermin and rot proof. The acrylic coating of the slates will reduce the potential growth of moss and lichen.

### General design considerations

Zeeland slate laid to BS 5534 will meet the strength requirements for the imposed and uniformly distributed wind and snow loads etc. The site exposure rating and the pitch of roof rafters will determine the size, pattern, lap and fixings for the slates. For UK and Northern Ireland locations, the latest version of BS 5534 will indicate the expected degree of exposure. Wind driven rain ratings less than 56.5 l/m<sup>2</sup> per spell are described as 'moderate' (see table 1) and those above 56.5 l/m<sup>2</sup> per spell are described as 'severe' (see table 2). Detailed guidance on wind load calculations is given in the latest version of BS 5534; and in BS EN 1991-1-4:2005 and 1991-1-3:2003 to calculate the wind action (design loads) on a roof it will be necessary for the designer to use two documents at the same time; the Eurocode standard BS EN 1991 Part 1-4, and the associated National Annex. The authors of the National Annex have advised that reference should also be made to PD 6688-1-1:2011. In locations where abnormal conditions may be anticipated such as elevated sites, coastal locations, areas of heavy snowfall etc., the recommendation for 'severe' should be followed. For buildings above 12m in height, the influence of increased windspeed can be determined using BS EN 1991-1-4.

Additional information can also be found in BS 8104: 1992. Where the location or construction might make a lower rafter pitch acceptable, designers are asked to seek advice.

**Table 1** Moderate exposure

less than 56.5 l/m<sup>2</sup> per spell

- In general, the recommendations below apply to rafter lengths of not more than 9m. The specifier should also take account of any abnormal local conditions that might apply.

| Pitch<br>deg | Slate Size<br>mm x mm | Minimum<br>headlap<br>mm | Slates<br>no/m <sup>2</sup> | Batten<br>gauge<br>mm | Average<br>weight<br>kg/m <sup>2</sup> |
|--------------|-----------------------|--------------------------|-----------------------------|-----------------------|--|
| 45°          | 600 x 300             | 90                       | 13.07                       | 255                   | 19.61                                  |
| 40°          | 600 x 300             | 90                       | 13.07                       | 255                   | 19.61                                  |
| 35°          | 600 x 300             | 90                       | 13.07                       | 255                   | 19.61                                  |
| 30°          | 600 x 300             | 90                       | 13.07                       | 255                   | 19.61                                  |
| 27.5°        | 600 x 300             | 100                      | 13.33                       | 250                   | 20.00                                  |
| 25°          | 600 x 300             | 100                      | 13.33                       | 250                   | 20.00                                  |
| 22.5°        | 600 x 300             | 100                      | 13.33                       | 250                   | 20.00                                  |
| 20°          | 600 x 300             | 110                      | 13.61                       | 245                   | 20.41                                  |

An allowance should be made for cutting and wastage for all exposures.

**Table 2** Severe exposure

greater than or equal to 56.5 l/m<sup>2</sup> per spell

- In general, the recommendations below apply to rafter lengths of not more than 6m. The specifier should also take account of any abnormal local conditions that might apply.

| Pitch<br>deg | Slate Size<br>mm x mm | Minimum<br>headlap<br>mm | Slates<br>no/m <sup>2</sup> | Batten<br>gauge<br>mm | Average<br>weight<br>kg/m <sup>2</sup> |
|--------------|-----------------------|--------------------------|-----------------------------|-----------------------|--|
| 45°          | 600 x 300             | 90                       | 13.07                       | 255                   | 19.61                                  |
| 40°          | 600 x 300             | 90                       | 13.07                       | 255                   | 19.61                                  |
| 35°          | 600 x 300             | 90                       | 13.07                       | 255                   | 19.61                                  |
| 30°          | 600 x 300             | 100                      | 13.33                       | 250                   | 20.00                                  |
| 27.5°        | 600 x 300             | 100                      | 13.33                       | 250                   | 20.00                                  |
| 25°          | 600 x 300             | 110                      | 13.61                       | 245                   | 20.41                                  |
| 22.5°        | 600 x 300             | 110                      | 13.61                       | 245                   | 20.41                                  |
| 20°          | 600 x 300             | 110                      | 13.61                       | 245                   | 20.41                                  |

An allowance should be made for cutting and wastage for all exposures.

**Table 3** Technical specification

| Size<br>mm | Holed<br>mm | Weight per 1000<br>kg | No. per<br>Pallet | Colour                 |
|------------|-------------|-----------------------|-------------------|------------------------|
| 600 x 300  | 90-110 lap  | 1500                  | 1000              | Blue Black<br>Graphite |

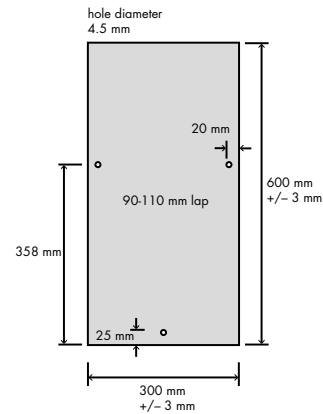

## Sitework

### Storage and handling

Zeeland slates should not be allowed to become wet during storage as this may cause efflorescence staining as a result of water accumulating between the slates surfaces. If stored outside for short periods, the polythene hood should be removed and the slates open stacked and covered with a tarpaulin. The slates should be carefully stacked on their longer edges with timber bearers, battens or boards between layers. The lowest layer must be arranged on a firm level base.

### Working

Zeeland slate can be cut using the traditional method of scribing and breaking over a straight edge. Angle grinders are not recommended due to nuisance dust levels. Additional fixing holes should be drilled using a 4.5mm drill bit. Holes should not be less than 20mm from the edge of the slate. After cutting or drilling remove all dust from the slate to avoid possible staining.

### Fixing

Zeeland slates must be laid in accordance with the latest version of Code of Practice for Slating and Tiling, BS 5534: and the Code of Practice for Workmanship on Building Sites – Slating and Tiling BS 8000:Part 6 2013. The roof structure should be checked to ensure that it is to a true line and squareness tolerance, and set out to ensure that:

- the minimum cutting of slates is necessary.
- the long edges of the slates are parallel to the direction at which the water will run off the roof. In some instances this may result in raking cuts to all the eaves and the ridges.
- the horizontal lines of the courses are straight and true.
- the perpendicular lines of the slate are to a true alignment and allow for a small 'perp' gap between slates (3mm ± 1mm).

The last two items are best achieved using a chalked line.

The method of fixing is to centre nail each slate with two 2.65mm x 30mm long copper nails and secure the tail of the slate with a copper disc rivet of suitable quality (0.45 x Ø 20mm base with a 20 x Ø 2mm pin) correctly bent down-slope through 90°.

Slate and a half and double slate sizes should be drilled to accept three nails and two disc rivets. At all verges and abutments, alternate slate courses must start with slate and half width to maintain bond. Slate and a half widths must be used if the half slate is less than 150mm wide. At valleys and hips where slates need to be cut on the rake, wide slates must be used to maintain an adequate width at the head or tail. At mitred hips on low pitched roofs wide slates should be used beneath the hip capping.

### Battens

Minimum batten sizes as recommended in Table 3 of the latest version of BS 5534 for use with fibre cement slates for roofing and vertical work:

| Span(mm)    | Batten size(mm) |
|-------------|-----------------|
| Up to 450mm | 38 x 25         |
| Up to 600mm | 50 x 25         |



To avoid splitting the batten, the maximum nail diameter should not exceed one tenth of the batten width. The ends of any batten should be fully supported and the length of any batten should not be less than 1.2m (except where this is unavoidable) and nailed to a maximum of 600mm centres. Where the roof is close-boarded, counter battens should be used down the slope in the roof on the line of the rafters. Counter battens should be of sufficient thickness to provide ventilation between the boarding and underlay.

The batten gauges for common laps are shown in tables 1 and 2.

### Underlay

Suitable underlay should have a minimum standard to BS 747: 2000 Type 1F and/or should have a BBA Certificate. The underlay should be draped over the rafters, or fully supported on boarding or sheathing, should allow any moisture to drain and should extend over the tilting fillet, fascia board and into the eaves gutter.

### Ventilation

The roof space and/or batten cavity must be ventilated in accordance with BS 5250:2011. Annex H of BS 5250:2011 gives guidance on the application of design principles. Sections H.3.3 - H.6 detail various roof constructions. Fibre cement slates should be considered an impermeable external covering. In cold roof construction the loft space must always be ventilated. If an LR "breather" underlay is used the batten space must also be ventilated. In warm roof construction with an HR underlay a ventilated void between the insulation and the underlay must be provided. If an LR "breather" underlay is used the underlay must be laid on the insulation and the batten space above must be ventilated, in addition an AVCL (impermeable membrane) must be provided between the insulation and the internal finish. Cembrit Ltd offer a comprehensive range of ventilation products to suit most applications and further advice is available on request.

### Lead staining risk

Lead develops a lead carbonate patina which, if washed over slates by rain or other moisture, causes unsightly staining. To prevent this reaction marring the work, it is advisable to treat all lead including soakers and flashings, with patination oil before any rain occurs, and not later than the day the lead is fixed. Patination oil, which is readily available from builders' merchants, should be applied following the manufacturer's instructions.

### Identification

A minimum of 25% of the slates are marked on the underside using the following format: BB104208NTB2 where the first character denotes the factory of origin; the second character the Strength Classification from EN 492 section 7.3.2; the next six numbers denote the shift and year of manufacture; NT denotes non-asbestos technology; and the final two characters show the production line and painting line used for manufacture.

### Typical specification

Roof to be covered with Zeeland Slates, size 600mm x 300mm, colour ....., laid to a minimum head lap of ..... mm. To be used with Cembrit slate vents, ridges and roof trims. An NBS specification is available either from our Technical Department or our website.

### Accessories

A full range of accessories including fibre cement undercloak/soffit strip is available. Please contact our Technical Department or see our website for full details.

### Supply

Cembrit Ltd's fibre cement Zeeland slates are supplied directly to approved accounts, roofing contractors and builders merchants. Prices are available on request from Cembrit Ltd.



The information contained in this publication and otherwise supplied to users of the company's products is based on the company's general experience, best knowledge and belief. However, because of factors beyond the company's knowledge and control, which can affect the use of the products, no warranty is given or implied with respect to such information.

The company's policy is one of continuous improvement. Cembrit Limited therefore reserves the right to alter specifications at any time and without notice.

As with all manufactured materials, colours and textures of slate may vary according to light and weather conditions. It is advisable to ask for samples of slate prior to specification and purchase.

Owing to this and limitations of the printing process, colours of slate in this brochure may only be taken as indicative.

Please ensure that you have the latest version of this datasheet by checking that the publication date on the top right of the front cover corresponds with the downloadable version on our website.

#### Branch listings

|                |                       |
|----------------|-----------------------|
| 1 London       | T +44 (0)20 8301 8900 |
| 2 Southampton  | T +44 (0)23 8061 5631 |
| 3 Bovey Tracey | T +44 (0)1626 835722  |
| 4 Llandow      | T +44 (0)1446 773777  |
| 5 Normanton    | T +44 (0)1924 890890  |

#### Cembrit Ltd

57 Kellner Road

London

SE28 0AX

Tel: +44 (0)20 8301 8900

Fax: +44 (0)20 8301 8901

[sales@cembrit.co.uk](mailto:sales@cembrit.co.uk)

